

Product data sheet

Characteristics

GVAPH02

TeSys, Mounting bracket for motor circuit breaker, TeSys Deca, alignment of extended rotary handle



Main

Range	TeSys
Product or component type	Mounting bracket
Device short name	GVAP
Accessory / separate part category	Control accessory

Complementary

Product compatibility	GV2APN01 GV2APN02 GV2APN03 GV2APN04
Height	174 mm
Width	65 mm
Depth	151 mm
Net weight	0.3 kg

Packing Units

Unit Type of Package 1	PCE
Number of Units in Package 1	1
Package 1 Height	9.2 cm
Package 1 Width	18.5 cm
Package 1 Length	27.2 cm
Package 1 Weight	417.0 g
Unit Type of Package 2	S03
Number of Units in Package 2	6
Package 2 Height	30.0 cm
Package 2 Width	30.0 cm
Package 2 Length	40.0 cm
Package 2 Weight	2.908 kg

Offer Sustainability

Sustainable offer status	Green Premium product
REACH Regulation	 REACH Declaration
EU RoHS Directive	Compliant  EU RoHS Declaration
Mercury free	Yes
China RoHS Regulation	 China RoHS Declaration

RoHS exemption information	Yes
Environmental Disclosure	Product Environmental Profile
Circularity Profile	End Of Life Information
WEEE	The product must be disposed on European Union markets following specific waste collection and never end up in rubbish bins

Contractual warranty

Warranty	18 months
----------	-----------

Mounting of External Operator GVAPH02 for Motor Circuit Breakers GV2L

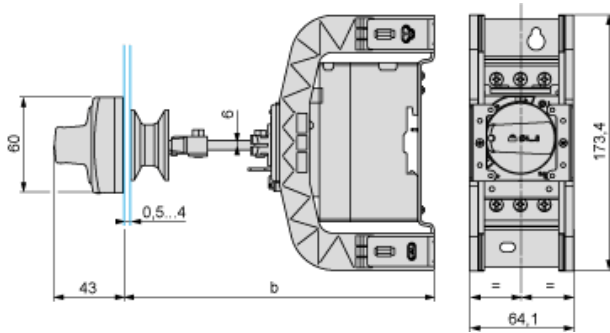

	b	
	Minimum	Maximum
GV2 APN.. + GV APH02	151	250
GV2 APN.. + GV APH02 + GV APK11	250	445

Door cut-out

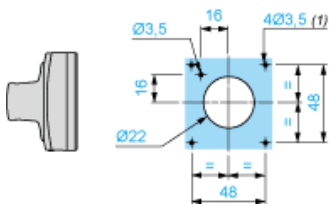

(1) For IP65 only.