

## Product data sheet

### Characteristics

# ISM11154

OptiLine 70 - stop end - PC/ABS - aluminium metallic

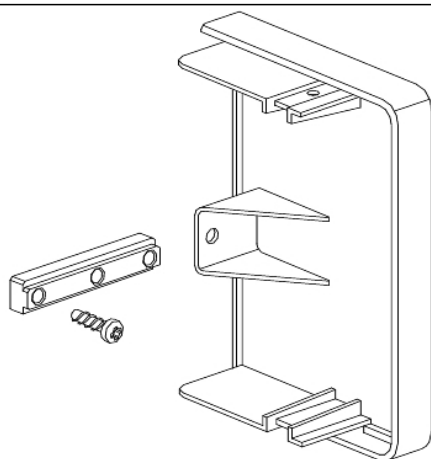

### Main

Range of product	OptiLine 70
Cabling installation system	Trunking
Product type	Stop end
Colour	Aluminium metallic
Quantity package 1 / unit	Set of 2

### Complementary

Trunking material	Aluminium
Trunking dimension	80 x 55 mm
Fixing mode	Screw Snap-fitted
Product material	PC/ABS painted
Length	21 mm
Height	64 mm
Width	56 mm

### Environment

Standards	73/23/EEC 93/68/EEC EN 50085-1:2005 EN 50085-1:2013/A1 EN 50085-2-1:2006 EN 50085-2-1:2011/A1 NF C 68-102
Operating temperature	-25...60 °C
IP degree of protection	IP40
IK degree of protection	IK07

### Packing Units

Unit Type of Package 1	PCE
Number of Units in Package 1	1
Package 1 Weight	24 g
Package 1 Height	2.1 cm
Package 1 width	5.6 cm
Package 1 Length	8.4 cm
Unit Type of Package 2	BAG
Number of Units in Package 2	2
Package 2 Weight	51 g
Package 2 Height	2.5 cm
Package 2 width	17.5 cm

Package 2 Length	20 cm
Unit Type of Package 3	S03
Number of Units in Package 3	150
Package 3 Weight	4.31 kg
Package 3 Height	30 cm
Package 3 width	30 cm
Package 3 Length	40 cm

### Offer Sustainability

Sustainable offer status	Green Premium product
REACH Regulation	<a href="#">REACH Declaration</a>
REACH free of SVHC	Yes
EU RoHS Directive	Pro-active compliance (Product out of EU RoHS legal scope) <a href="#">EU RoHS Declaration</a>
Toxic heavy metal free	Yes
Mercury free	Yes
RoHS exemption information	<a href="#">Yes</a>
China RoHS Regulation	<a href="#">China RoHS Declaration</a>
Environmental Disclosure	<a href="#">Product Environmental Profile</a>

### Contractual warranty

Warranty	18 months
----------	-----------