

Product data sheet

Characteristics

XB4RFB01

Harmony XB5R, Wireless and batteryless package, Wireless metal 22mm black pushbutton, non configurable receiver, 24V DC



Main

Range of product	Harmony XB4R
Product or component type	Wireless and batteryless package
Device short name	XB4R
Head material	Metal
Frequency	2405 MHz for transmitter 2405 MHz for receiver
Emission class	5M00G7W
Antenna type	Omnidirectional

Complementary

Control type	Wireless and batteryless push-button Ø 22 mm assembled on fixing collar
Type of receiver	Non-programmable receiver (1 relay)
[Us] rated supply voltage	24 V DC
Kit composition	1 fixing collars 1 diameter: 22 mm 1 push-button head diameter: 22 mm 1 transmitter 1 receiver 1 set of caps
Communication port protocol	Zigbee conforming to IEEE 802.15.4
Max power consumption in W	1 mW
Number of channels	1
Modulation Technique	O-QPSK
Bandwidth	5 MHz
Antenna gain	0 dBi
Customizable	No
Compatibility code	XB4R
[Us] rated supply voltage	24 V

Environment

Product certifications	CCC[RETURN]C-Tick[RETURN]GOST[RETURN]CSA[RETURN]JUL
Marking	CE
Standards	UL 508 EN/IEC 60947-1 CSA C22.2 No 14 EN/IEC 60947-5-1
Radio agreement	ARIB T66 RSS ICASA SRRC FCC ANATEL

The information provided in this documentation contains general descriptions and/or technical characteristics of the performance of the products contained herein. This documentation is not intended as a substitute for and is not to be used for determining suitability or reliability of these products for specific user applications. It is the duty of any such user or integrator to perform the appropriate and complete risk analysis, evaluation and testing of the products with respect to the relevant specific application or use thereof. Neither Schneider Electric Industries SAS nor any of its affiliates or subsidiaries shall be responsible or liable for misuse of the information contained herein.

Packing Units

Unit Type of Package 1	PCE
Number of Units in Package 1	1
Package 1 Height	9.300 cm
Package 1 Width	10.500 cm
Package 1 Length	11.000 cm
Package 1 Weight	235.000 g
Unit Type of Package 2	S03
Number of Units in Package 2	16
Package 2 Height	30.000 cm
Package 2 Width	30.000 cm
Package 2 Length	40.000 cm
Package 2 Weight	4.000 kg

Offer Sustainability

REACH Regulation	REACH Declaration
EU RoHS Directive	Pro-active compliance (Product out of EU RoHS legal scope) EU RoHS Declaration
Mercury free	Yes
China RoHS Regulation	China RoHS Declaration
RoHS exemption information	Yes
WEEE	The product must be disposed on European Union markets following specific waste collection and never end up in rubbish bins

Contractual warranty

Warranty	18 months
----------	-----------

Non-Programmable Receiver

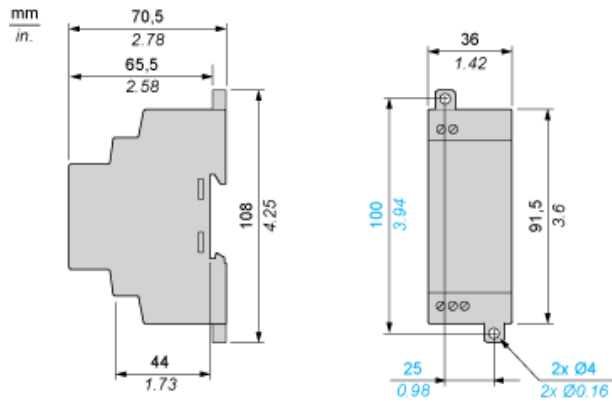

Wireless and Batteryless Pushbutton - Transmitter

With Metal Pushbutton without Cap

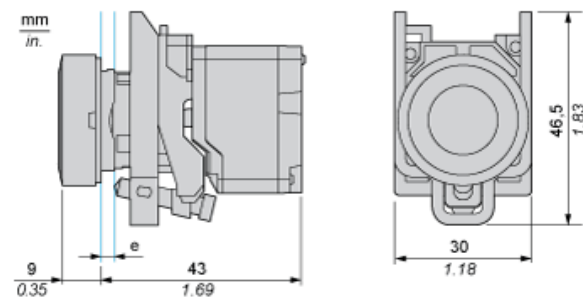

e: panel thickness 1 to 6 mm / 0.039 to 0.24 in.

Receiver Clearance

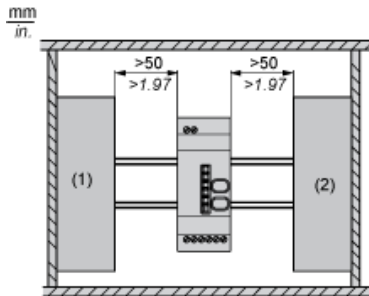

- (1) Drive
- (2) Power Supply or PLC

Receiver Mounting

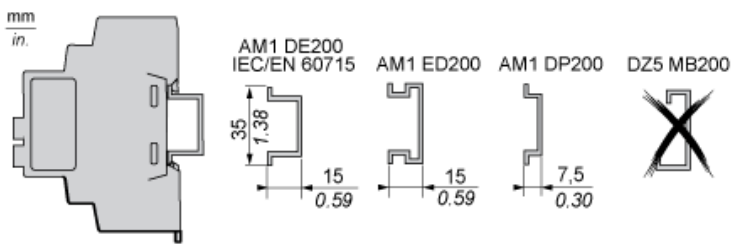

Non-Programmable Receiver

Wiring Diagram

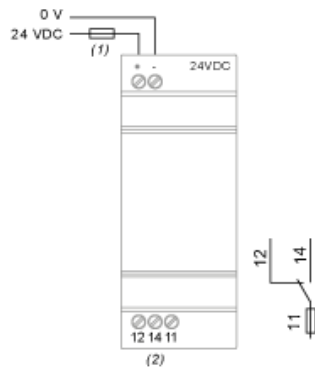

- (1) 125 mA fast-blow fuse
- (2) $I_{max} = 3 A$